



# VoltMaster® Intelligent Transformer

## Product order codes for standard 0-10V VoltMaster.

For DSI or DALI digital versions, add suffix /DSI or /DALI eg VMD300/12/SO/DSI

Single outlet	Multi outlet
VMD300/12/SO	VMD300/12/MO
VMD400/12/SO	VMD400/12/MO
VMD400/24/SO	VMD400/24/MO
VMDE300/24/SO	VMDE300/24/MO

All VoltMasters are now dimmable with order codes as above. Where dimming is not required, leaving the dimming terminals (C1-C4) unconnected will deliver the optimum maximum voltage to the lamps: 11.8V for 300/12, 400/12, E300/12 options, 23.6V for 400/24.

For dimming, VoltMaster reduces the brightness of the lamps according to the level of the 0-10V analogue signal on its dimming terminals, and this reduced brightness is accurately stabilised against mains voltage and load variations even at lowest brightness levels.

VoltMaster provides isolation to standards compatible with SELV (Safe Extra Low Voltage) lighting and is suitable for use with individual luminaires, tracks and high-wire systems.

VoltMaster conforms to the following standards for EMC: BSEN55103-1, BSEN55022 Class B, BSEN55103-2, BSEN61000-4-2, BSEN61000-4-3, BSEN61000-4-4, BSEN61000-4-5, BSEN61000-4-6, BSEN61000-4-11, following the provisions of EU EMC Directive/s 89-336-EEC and 92-31-EEC. The applicable safety standard is BSEN61558-2-6, following the Principal Elements of the Safety Objectives of the Low Voltage Directive 72-23-EEC.

Load wiring design must observe the following max cable volt drops:

VMD300/12	3V	VMD400/12	3V
VMDE300/12	7V	VMD400/24	6V

Load wiring design datasheets are available from the 'technical guides' link at [www.multiload.co.uk](http://www.multiload.co.uk) or by contacting Multiload.

## Product Dimensions

**weight:** 9kg

**finish:** stove enamel

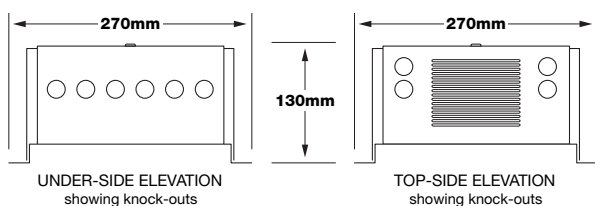
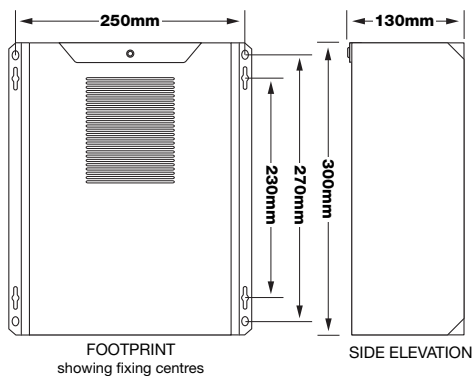

Fig 1. Multi-Outlet

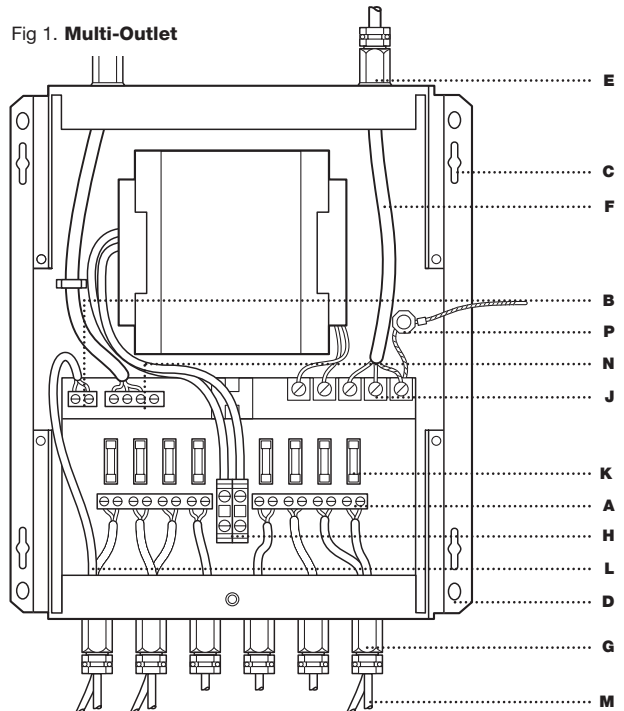
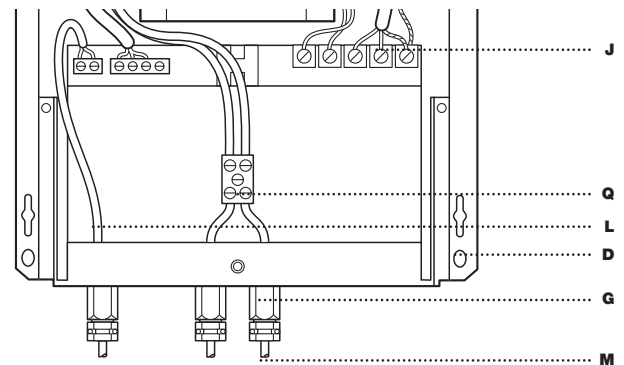

Fig 2. Single-Outlet



## Key

- A Secondary low voltage multi-outlet terminal pairs.** For one or more individual cables to single lamps. Maximum cable size 4mm<sup>2</sup>
- B Sensing terminal pair.** If this terminal pair is not properly connected the unit will not give full brightness. See **Sensing Connection** overleaf.
- C Keyhole slots** for initial fixing – 4 in total.
- D Fixing / mounting holes** for secure fixing – 4 in total.
- E Cable clamps\*** – 4 x 20mm knockouts provided.
- F Mains supply cable** – three core (live, neutral & earth). See **mains supply connection** overleaf.
- G Cable clamps\*** – 12 x 20mm knockouts provided.
- H Terminal pair for track or single outlet.** Use instead of individual terminal pairs (A). Maximum cable size 10mm<sup>2</sup>
- J Mains supply terminal block.** Mandatory earth must be connected.
- K Output fusing per individual terminal pair (A)**  
See **Output fusing** overleaf for fuse function.
- L Sensing cable.\***
- M Low voltage cables.\***
- N Dimming signal terminals**
- P Earth connection for cover.**
- Q Single-outlet terminal** – for track, high-wire or distribution box connection. Max cable size 10mm<sup>2</sup>

\* not supplied with unit

## Installation design

Before work is undertaken, the installation should be designed and a wiring plan prepared for the load wiring (see Load Wiring Design\*). It should give VoltMaster positions, outlet numbers, cable lengths and sizes and voltage sensing point: see Sensing Connection.

**NB.** If installing in a cupboard provide ventilation to avoid overheating. Do not mount unit on a vertical surface with the transformer below secondary outlets.

Installation should be carried out by a suitably qualified person in accordance with good electrical practice and the appropriate national and local wiring regulations.

**Fitting cable clamps or conduit:** Remove appropriate knock-outs in the end plates before installation to enable the fitting of the cable clamps/glands or conduit. The cover must be earthed: check and, if necessary, reinstate the earthing connection before applying power. **NB.** Cables and clamps not provided.

## Mains supply connection

VoltMaster must be connected to a clean unaltered mains supply and should **not** be connected to the output of mains dimmers.

Switch off mains electrical supply before commencing installation. Feed mains supply cable through cable clamp and connect wires into respective terminals in terminal block (J: Fig.1). VoltMaster must be earthed. To ensure the mains cable does not touch the transformer, do not have too much excess cable inside VoltMaster.

**Mains fusing:** VoltMaster is protected by a (F) HRC fuse. This is not a customer-replaceable fuse and should not blow in normal circumstances. If it does, contact Multiload.

## Output connection

### Total loading

The unit will control any load from 35W up to a total maximum equal to the unit rating: 300W for the VMD300/12 and VMDE300/12 and 400W for the VMD400/12 and VMD400/24.

### Overall outlet to track, high wire or distribution box

Lamps up to the total max unit rating may be connected to the track, high wire or distribution box. Track is connected to the large terminal block (H:Fig.1, Q:Fig 2) – which accept up to 10mm<sup>2</sup> cable.

### Standard multi-outlet to individual light fittings

Lamps are individually wired back to the individual terminal pairs (A:Fig.1). Each individual terminal pair will accept a single cable of up to 4mm<sup>2</sup>. Thicker cable or multiple cables could be terminated into suitable pin or blade crimps or junction box to facilitate connection to the terminal pair.

The connection to individual terminal pairs on either side of the large green terminal should be balanced as equally as possible: in any case no more than 225W on any one side.

### Cable connection

Feed the necessary cables to the luminaire(s) through the cable clamps if used. Securely connect cable(s) to appropriate terminal pairs (A/H:Fig.1). Tighten the cable clamps.

### Output fusing

VoltMaster is supplied fitted with Quick Acting (Ceramic) F10A fuses (max 75W per terminal pair) (K:Fig.1).

### Fuse replacement

The unit will accept 1<sup>1</sup>/<sub>4</sub> x 1<sup>1</sup>/<sub>4</sub> size '0' or 20mm x 5mm fuses.

- 1 Ensure mains supply is switched off.
- 2 When removing fuse do not over-stress or deform clip contacts.
- 3 Ensure fuse caps and clip contacts are clean (avoid handling).
- 4 Locate fuse centrally in contacts before inserting.

\* See Load Wiring Design: VMDLW300 series for details of voltage sensing point. Available from the 'technical guides' at [www.multiload.co.uk](http://www.multiload.co.uk) or by contacting Multiload.

## Dimming Connection

### Control by signalling system (0-10V or 1-10V)

The analogue signal is connected to the terminals (N:Fig.1) C1 = 0V (negative) and C4 = signal (positive): maximum cable size 2.5mm<sup>2</sup>. In line with the industry standard, VoltMaster requires sink current capability from the control system. VoltMaster reverts to full brightness on signal disconnection.

### Control by digital signalling (DSI or DALI)

The digital signal is connected to the input terminals on the DSI or DALI interface situated within the unit.

### Manual control

VoltMaster can be controlled by any Multiload RPS3 rotary control module, which connects to terminals C1, C2 and C3 (N:Fig.1). Maximum cable size 2.5mm<sup>2</sup>. Several VoltMasters may be connected to a single module.

## Sensing connection

It is imperative that the sensing cable (L:Fig.1) is connected on installation. Failure to connect this cable will cause the unit to deliver a reduced fixed secondary voltage to the luminaires.

Connect cable (L:Fig.1) into voltage sensing terminals (B) and other end to the voltage sensing point. The sensing cable carries 11.8V (23.6V) RMS and hardly any current.

For multi-outlet, we recommend the sensing cable should be a min of 1mm<sup>2</sup> (min 10A rating) and its exact length is unimportant.

When the sensing cable is connected to a track, or similar, fed from the large terminals (H:Fig.1 or Q:Fig.2) we recommend sensing cables should be minimum 2.5mm<sup>2</sup>. Thinner cable can be used if suitably protected at the 'voltage sensing point'\*.

## VoltMaster functions

### Short circuit protection

Single outlet to track, high-wire system or distribution box (Q:Fig.2). If a short circuit occurs on the output circuit VoltMaster will shut down to almost zero voltage; monitor output circuit continuously; restart 10-15 seconds after the short has been corrected.

Each individual terminal pair (A:Fig1) is protected by a 10A (F) fuse. If a short circuit occurs on one of the outlets, either the fuse will blow immediately or VoltMaster will shut down for 10-15 secs and then restart, blowing the fuse in the process which allows the remaining outlets to resume operation.

### Overload protection

If unit is overloaded it will shut down for approx 15 secs, and then gradually ramp the lamps up towards the set brightness. If the overload persists this cycle will be repeated until the overload is removed – when normal operation will be automatically resumed.

## Fault Diagnosis

**Output showing approx 7V (14V) RMS (reduced brightness):** check that sensing connection is made.

**Lamps receiving more than 11.8V (23.6V)RMS:** check that sensing cable is connected to correct voltage sensing point.

**Lamps look off:** 1. Check mains supply to unit. 2. Check for output short circuit: disconnect output connections in turn, until at some point lamps should relight. Remove short circuit on relevant load before reconnection. If lamps do not light at all, contact Multiload.

**Lamps at very dim level (dimming units only):** check dimming signal: disconnect all connections to C1 C2 C3 C4 – if sensing cable is still connected then lamps should show full brightness – reconnect correct dimming signal.

Lamps continually tripping **off** and slowly ramping up after approx 15 ses: check for overload: check lamp wattages and number of lamps connected.

**VoltMaster:** All data refers to MO and SO units unless otherwise stated

Condition/feature	Requirement (R)/Capability (C)	Parameter	Value/units	Note	Type / comment	
Electrical supply (mains input)	<b>R</b> Regular sine wave Frequency	Voltage	207-265V		Mandatory Earth must be connected.	
			48-62Hz			
Ambient conditions	<b>R</b> Non-condensing	Temperature	0-45°C	1	VMD300/12, VMD400/24 VMD400/12 VMDE300/12 Derate for higher temperatures	
			0-40°C	1		
			0-40°C			
	IP rating		IP20			
Output	<b>C</b> Isolated SELV compatible	Nominal	12V	2	VMD300/12 and VMD400/12 VMDE300/12	
		Voltage	24V	2		VMD400/24
		Max. load (nominal)	300W	3		VMD300/12
			400W	3		VMD400/12, VM400/24
		Min. load	35W			Ensures correct operation
Voltage sensing	<b>R</b> 2-wire cable must be connected to track/lamp fitting	Min. cable size to track	2.5mm <sup>2</sup>		If sensing cable not connected output freezes at approx half brightness	
		Min. cable size to fused fitting	1mm <sup>2</sup>			
		Sensing cable terminal x 2	Cable size acceptance	2.5mm <sup>2</sup>		Use load knockout
Dimming	<b>R</b> Dimming signal terminal	Cable size acceptance	2.5mm <sup>2</sup>		Analogue sig:C1:0V & C4:0-10V C1,C2,C3 potentiometer connect	
SoftStart	<b>C</b> increases output slowly from zero	Ramp up time to max.	5sec	4	100% effective	
Overload protection	<b>C</b> Trips and reduces output quickly to zero.	Trip threshold	110%		ie. trips when overloaded by approx 10% of rated full load	
Short circuit protection	<b>C</b> Trips and reduces output quickly to zero.	Response time	<50ms		100% effective	
Recovery after protection trip	<b>C</b> Soft starts after approx. 10 second delay	Total time to recovery	15sec	5	If the fault persists, the output continually ramps up to a level which operates the trip again	
<b>Multi outlet units only</b> Output terminations. Total lamp wattage up to maximum load rating	<b>either:</b> <b>C</b> 8 x fused terminal pairs for individually wired lamp fittings	Cable size acceptance	4mm <sup>2</sup>	6		
			Max watts per terminal pair	100W		7
			150W	7	VMD400/24	
	<b>or:</b> <b>C</b> Large Green Terminal pair for track	Cable size acceptance	10mm <sup>2</sup>	6 8	Total lamp wattage up to maximum load rating.	
<b>Single outlet units only</b> Output terminations. Total lamp wattage up to maximum load rating	Ceramic terminal pair	Cable size acceptance	16mm <sup>2</sup>			
<b>Multi outlet units only</b> Output fuse rating	One per fused terminal pair	As fitted	10A		GLASS quick-acting 5 x 20mm	
Mains supply termination	<b>R</b> L, N,  (Mandatory Earth)	Cable size acceptance	2x2.5mm <sup>2</sup>		3-way terminal block 2 x 20mm knockout provided	
Mains safety fusing	<b>R</b> Not customer-replaceable	Rating	5A		Fast Ceramic 5 x 20mm	

**Notes:**

- 1 Provide ventilation if installing in cupboard.
- 2 At full brightness output adjusts to give 11.8V (23.6V) at lamps.
- 3 Loading capability includes allowance for lamp wattage tolerance.
- 4 SoftStart operates at switch-on, after mains interruptions and after protection trip delay.
- 5 For short circuit trip level is very low (no light will show)
- 6 Use either 8-off terminals or large green terminal.
- 7 Distribute loads evenly on each side off distribution outlet board if using 8-off terminals.
- 8 Large green terminal is for wiring to track, high-wire or distribution box.